



Important Instructions to examiners:

- 1) The answers should be examined by key words and not as word-to-word as given in the model answer scheme.
- 2) The model answer and the answer written by candidate may vary but the examiner may try to assess the understanding level of the candidate.
- 3) The language errors such as grammatical, spelling errors should not be given more Importance (Not applicable for subject English and Communication Skills).
- 4) While assessing figures, examiner may give credit for principal components indicated in the figure. The figures drawn by candidate and model answer may vary. The examiner may give credit for any equivalent figure drawn.
- 5) Credits may be given step wise for numerical problems. In some cases, the assumed constant values may vary and there may be some difference in the candidate's answers and model answer.
- 6) In case of some questions credit may be given by judgement on part of examiner of relevant answer based on candidate's understanding.
- 7) For programming language papers, credit may be given to any other program based on equivalent concept.

Q1. Attempt any six:

i) Isolated system: it is a system in which there is no transfer of mass and energy between the system and surrounding .eg. Thermoflask. (2M)

ii) Define: a) **Point function:** the property whose change depends on the initial and final state of system and not on the path adopted to bring about change is called point function. (1M)

b) Path function: the thermodynamic quantities which are dependent on path followed between two end states of the process and independent of the two end states are called path functions. (1M)

iii) Charle's law: it states that if a perfect gas is heated at constant pressure , its volume varies directly with the absolute temperature.

At constant pressure, $V \propto T$, $\frac{V}{T} = \text{constant} \dots \dots \dots (2M)$

iv) List of boiler accessories: (any four) (2M)

- a) Feed pump.
- b) Economizer.
- c) Super heater.
- d) Air pre heater.
- e) Steam separator

v) Isochoric process:

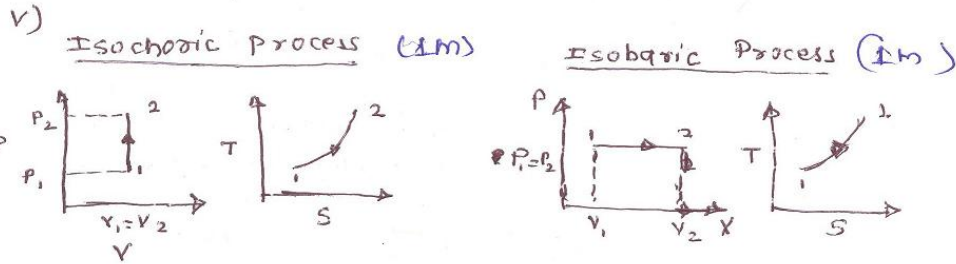

vi) Application of steam nozzle: (2M)

- a) It is used in steam turbine of power plant.
- b) It is used to measure discharge of fluid.
- c) In injector for pumping feed water into boiler.
- d) For removing air from condenser using injector.

vii) Dalton's law of partial pressure: this law states that " the total pressure exerted by a mixture of air and water vapour on the walls of container is the sum of partial pressure exerted by air separated and that exerted by vapour separately at common temperature of the condenser". (2M)

viii) Emissivity: it is defined as total emmisse power to toatal emmisse power of a black surface, at the same temperature. (1M)

Transmitivity: it is the ratio of transmitted energy to incident energy. (1M)

b) Attempt (any two): (4M)

Open system	Close system
a) Both mass and energy crosses the system boundary.	b) In this system there is no mass transfer taking place between system and surrounding.



Eg. A gas enclosed in cylinder with inlet and outlet

E Heating of gas in a closed vessel.

ii) Steady flow energy equation

For 1 kg of gas

$$Q + h_1 + gZ_1 + (1/2) C_1^2 = W + h_2 + gZ_2 + (1/2) C_2^2$$

Where, Q= heat supplied in KJ/kg.

h_1, h_2 = enthalpies of substances entering into system, leaving from system in KJ. Systems m/s

C_1, C_2 = velocities at entering and leaving.

Z_1, Z_2 = heights from datum in meter.

W= work perform KJ/sec or Watt. (1M)

Turbine:

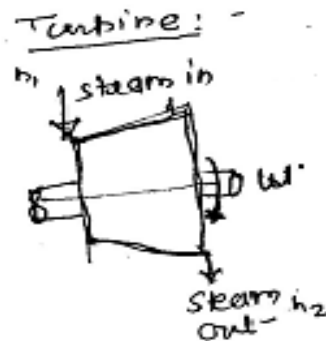

It is the device which converts heat energy (energy of working substance) into work.

Applying S.F.E.E ,

$$Q + h_1 + gZ_1 + (1/2) C_1^2 = W + h_2 + gZ_2 + (1/2) C_2^2$$

Since $Q= 0, C_1, C_2= 0$ where,

Q= heat supplied in KJ/kg.

h_1, h_2 = enthalpies of substances entering into system, leaving from system in KJ. Systems m/s



Subject Code: 17410

C_1, C_2 = velocities at entering and leaving.

Z_1, Z_2 = heights from datum in meter.

W = work perform KJ/sec or Watt. (1^{1/2} M)

$W = h_1 - h_2$ (1^{1/2} M)

Nozzle:

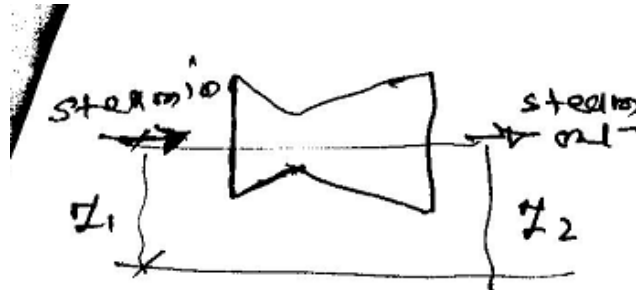

It is the passage of varying cross sectional area in which heat energy of fluid is converted into kinetic energy.

Applying S. F. E. E ,

$$Q + h_1 + gZ_1 + (1/2) C_1^2 = W + h_2 + gZ_2 + (1/2) C_2^2$$

Since $Q = 0, Z_1, Z_2 = 0, W = 0$ where,

$$h_1 - h_2 = (C_2^2/2) - (C_1^2/2)$$

$$2(h_1 - h_2) = C_2^2 - C_1^2$$

$$C_2 = \sqrt{2(h_1 - h_2) + C_1^2}$$
 (1^{1/2} M)

iii) Heat is that form of energy which transferred from one body to another on account of temperature difference. Heat is represented by symbol Q and is measured in KJ. Heat energy may be transferred in three ways of i) conduction, ii) convection, iii) radiation. (1^{1/2} M)

Work: work is a transient form of energy. When a force acts upon a body causing the body to move and to overcome continually a resistance. Work is said to be done.

Work done = force x displacement

$$= F \times S = Nm = \text{Joule}$$
 (1^{1/2} M)



SI unit for work done is joule or KJ. Work done by system is positive work done. Work done on system is negative work done. As work is easily converted into other form as compared to heat energy hence it is high grade types of energy. Eg. Generating electrical energy by generator, running by turbine (performing the work). (1M)

Q2. Attempt any four of the following: (4M)

Work	Internal energy
1. When a force acts upon body and body undergoes a displacement, the work is said to have been done.	1. Internal energy of a substance may be defined as the algebraic sum of internal kinetic energy and internal potential energy of its molecules.
2. Work is a transient form of energy	2. It is the energy stored within the substance and it is due to the motion and relative position of the molecules.
3. Work done expressed in Joule.	3. It is also expressed in joules.
4. Work done= force x displacement =Nm =joules	4. Change in internal energy $\Delta u = m C_v (T_2 - T_1) = u_2 - u_1$

b) PMM-I: If a machine is thought, which will give output without input energy then it is called PMM-I.

(2M)

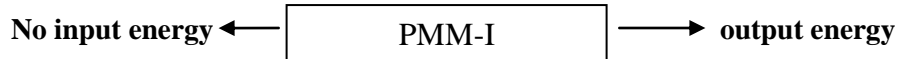

PMM-II: - A machine will give the 100 % output by receiving heat continually is known as PMM-II.

(2M)

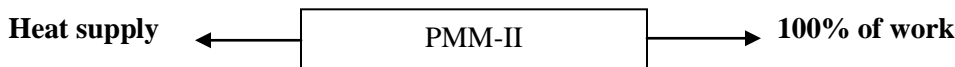

c) Kelvin Planck statement: It states that, "it is impossible to construct a heat engine, which while operating in cyclic process, will produce no effect other than transfer of heat from a single thermal reservoir and performance an equivalent amount of work.



Subject Code: 17410

Clausius statement: It state that “ it is impossible to construct a heat pump , which while operating in a cyclic process, which will produce no effect other than transfer of heat from lower temperature reservoir to higher temperature reservoir (2 M)

Equivalence of two statements: any one from a,b (2 M)

a) **Violation of Kelvin plank statement resulting into violation of clausius statement.**

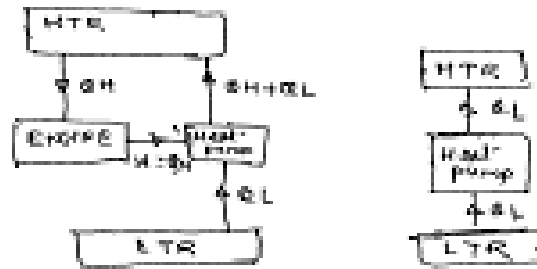

HTR - higher temperature reservoir.

LTR- Low temperature reservoir.

Consider a heat engine which absorbs heat Q_H from HTR. It converts this heat entirely into work W in a cyclic process, by exchanging heat only one reservoir, thus violating Kelvin plank statement of second law.

Now let this engine drive a heat pump which will heat Q_L from LTR and will deliver the same to HTR, thus violates Clausius statement.

b) **Violation of clausius statement resulting into violation of Kelvin plank statement.**

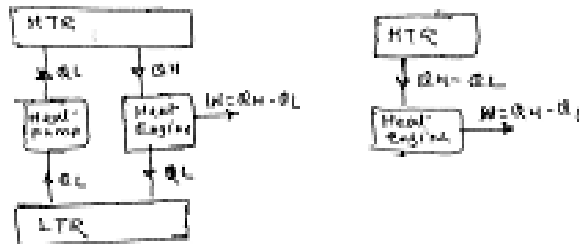

- Consider a heat pump removing heat Q_L from LTR and delivering it to HTR in a cyclic process. This violates clausius statement or second law. Now consider a heat engine operating between the same reservoirs. Let heat Q_H be supplied to heat engine the heat engine reject heat Q_L to LTR producing work ($W=Q_H-Q_L$). There no change in heat content of low



temperature reservoir and heat engine , high temperature and heat pump taken together will be combined device which absorb $Q_H - Q_L$ from single thermal reservoir, it converts this heat into work $W = Q_H - Q_L$ without rejecting heat to LTR. This violates Kelvin plank statement.

d)Isothermal Process:

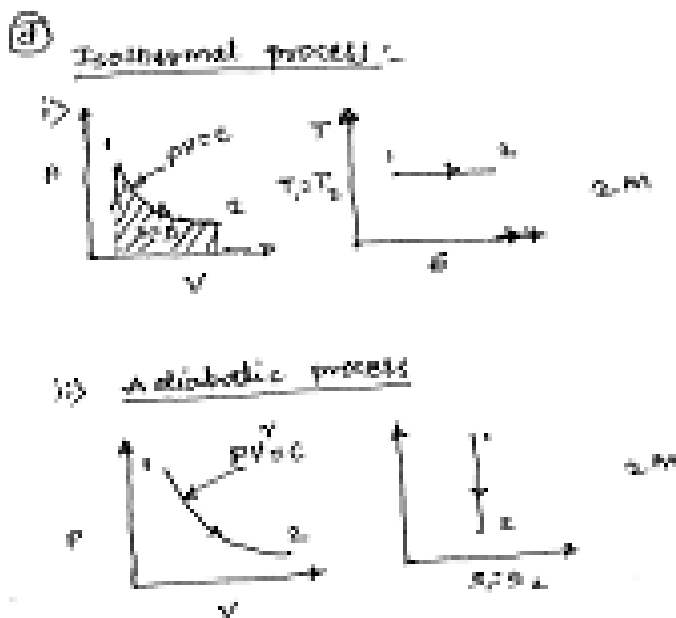

e) Avogadro's law: - The law state that equal volumes of all gases at the same temperature and pressure contain same number of molecules. (2M)

Under identical condition of the temperature and pressure, one cubic metre of oxygen (O₂) has a weight of oxygen is 32. Therefore molecule of O₂ has a weight which is (32/2) = 16 times of weight of molecules of H₂. Since one cubic meter of these gases contain the same number of molecules and a molecule of O₂ weighs 16 times as much as a molecule of H₂. (2M)

f) Given: $V_1 = 2.3 \text{ m}^3$, $T_1 = T_2 = 270 + 273 = 543 \text{ K}$, $P_1 = 0.1 \text{ MPa} = 0.1 \times 10^3 \text{ KPa}$, $P_2 = 4 \text{ KPa}$, $m = ?$

Sol: assume $R = 0.287 \text{ KJ/Kg}$ for air. Without changing temperature

$$\frac{P_1 V_1}{T_1} = \frac{P_2 V_2}{T_2}$$

$$P_1 V_1 = P_2 V_2$$

$$0.1 \times 10^3 \times 2.3 = 4 \times V_2$$

$$V_2 = 57.5 \text{ m}^3 \dots\dots\dots (2m)$$

By applying characteristics equation



$$P_2 V_2 = mRT_2$$

$$4 \times 57.5 = m \times 0.287 \times 543$$

$$m = 1.47 \text{ kg} \dots\dots\dots (2m)$$

Q. 3 (a) **Isothermal process** (Fig p-v , T-S diagram -2 marks; explanation- 2 marks)

- A process, in which temperature remains constant.

- There is no change in temperature.

- There is no change in internal energy.

- There is no change in enthalpy.

- It follows Boyle's law, $P \propto \frac{1}{V} = \text{constant}$

$$PV = \text{Constant}$$

$$P_1 V_1 = P_2 V_2 = C$$

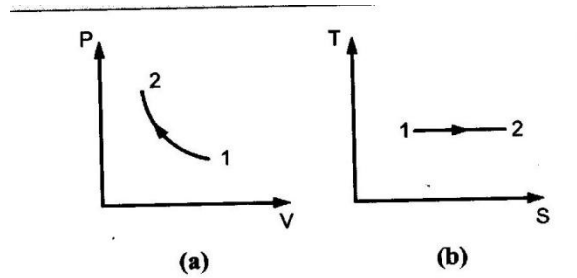

(b) **Define** (each definition -2 marks)

(i) **Dry saturated steam** - The steam contains no moisture at saturation temperature is known as dry saturated steam.

(ii) **Wet steam**- When steam contains some water particles in suspended form, is known as wet steam. The suspended water particles are known as moisture .

(c) **Steam generation process at const pressure.** (T-S diagram – 2 marks; H – S diag. -2 marks)

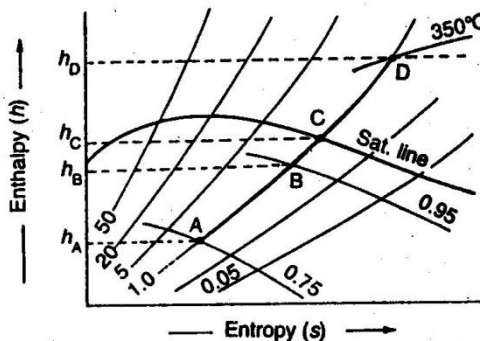
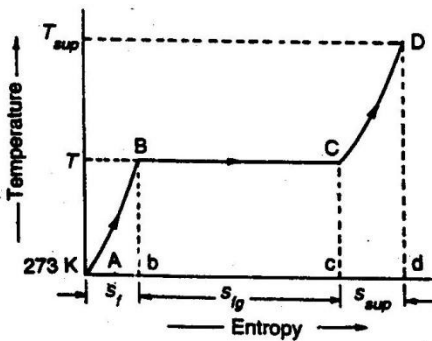



(d) From steam table, at 3 MPa pressure of dry & saturated steam,

$$h_g = 2804.2 \text{ kJ/kg} ; s_g = 6.1869 \text{ kJ/kg} ; v_g = 0.06668 \text{ m}^3/\text{kg} ; u_g = 2604.1 \text{ kJ/kg}$$

Hence for 3 kg of steam,

$$\text{Enthalpy} = h_g \times 3 = 2804.2 \times 3 = \mathbf{8412.6 \text{ kJ}} \quad (1 \text{ mark})$$

$$\text{Entropy} = s_g \times 3 = 6.1869 \times 3 = \mathbf{18.5607 \text{ kJ}} \quad (1 \text{ mark})$$

$$\text{Volume} = v_g \times 3 = 0.06668 \times 3 = \mathbf{0.20004 \text{ m}^3} \quad (1 \text{ mark})$$

$$\text{Internal energy} = u_g \times 3 = 2604.1 \times 3 = \mathbf{7812.3 \text{ kJ}} \quad (1 \text{ mark})$$

(e) **Constant enthalpy process** (throttling process)

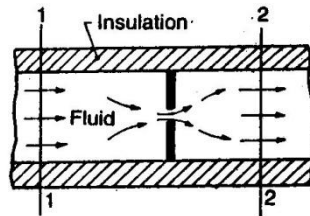

During this process, fluid is forced out by its pressure through the restricted opening or aperture. The aperture is so narrow that due to frictional resistance between the fluid & the sides of the aperture, the velocity of the out coming fluid is almost reduces to zero. The K. E. is converted to heat by friction. Hence if throttled, the dry steam will be superheated. (2 marks)

It may be noted that during a throttling process,

1. No heat is supplied or rejected (i.e. $q_{1-2} = 0$).
2. No work is done ($w_{1-2} = 0$).
3. No change in internal energy ($du = 0$).
4. The enthalpy or total heat of the fluid remains constant ($h_1 = h_2$) (2 marks)

(f) **The function** of air preheater is to increase the temperature of air before it enters the furnace. It is generally placed after economizer.

Advantages

- (1) Preheated hot air gives higher furnace temperature which results in more heat transfer to water & thus increases evaporative capacity per kg of fuel.
- (2) Increase of about 2% in the boiler efficiency for 35-40⁰ C rise in temperature of air.
- (3) Better combustion with less soot, smoke & ash.
- (4) It enables a low grade fuel to be burnt with less excess air.

(Function – 2 marks, Advantages-2 marks)

Q4 Attempt any four.



(a) Classification of steam turbine. (any four – 4 marks)

(i) According to working principles:

- (a) Impulse turbine
- (b) Reaction turbine
- (c) Impulse – reaction turbine

(ii) According to no. of stages of expansion of steam.

- (a) Single stage turbine
- (b) Multi stage turbine

(iii) According to position of shaft axis

- (a) Horizontal axis turbine
- (b) Vertical axis turbine

(iv) According to their nature of steam supply

- (a) High pressure turbine
- (b) Low pressure turbine

(v) According to direction of steam flow

- (a) Axial flow turbine
- (b) Radial flow turbine
- (c) Tangential flow turbine

(vi) According to exhaust steam pressure

- (a) Condensing type steam turbine
- (b) Non - Condensing type steam turbine

(b) Mach number (4 marks)

- It is the ratio of (V) to the sonic velocity © of compressible fluid. Hence $M = \frac{V}{A}$

- For subsonic velocity ($V < C$, $M < 1$), dA and dv must be opposite in sign (divergent part of nozzle) i.e. increase of cross-sectional area causes of reduction of velocity vice versa.

- For supersonic velocity ($V > C$, $M > 1$), dA and dV are same. An increase of cross sectional area (divergent part) causes an increase of velocity and vice versa.

- When $M = 1$ ($V = C$), dA must be zero since second derivative is positive, A must be minimum. The velocity of flow equal to sonic velocity, i. e. throat of the nozzle.

(c) Impulse turbine (fig. – 2 marks, explanation -2 marks)

- Impulse turbine consists of one set of nozzle mounted on a stationary diaphragm which is followed by one set of moving blade ring for a single stage impulse turbine.

- The high velocity steam jet are obtained by complete expansion of steam in the stationary nozzles fitted in diaphragm then this high velocity steam passes through moving blades with no drop in pressure but gradual reduction in velocity.

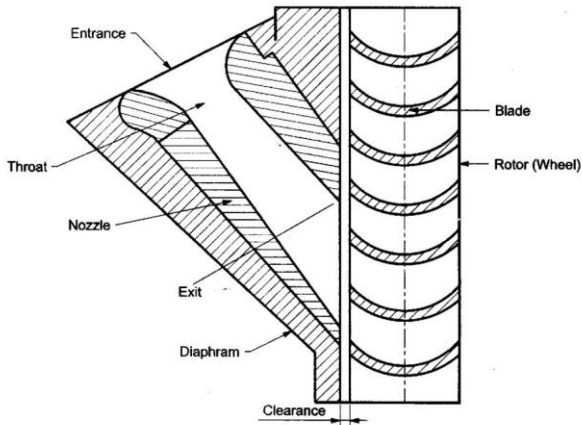

Fig: Simple impulse turbine

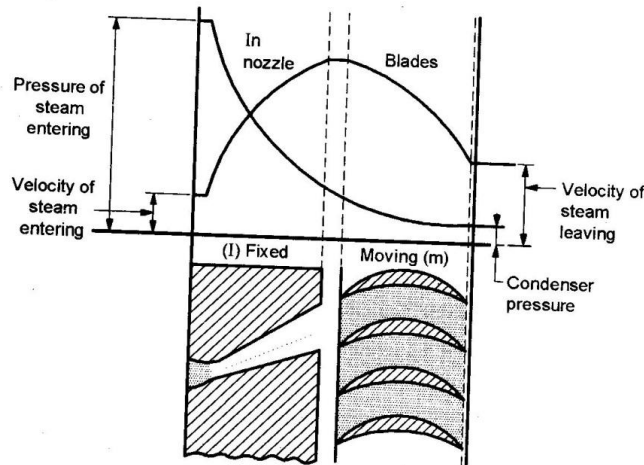
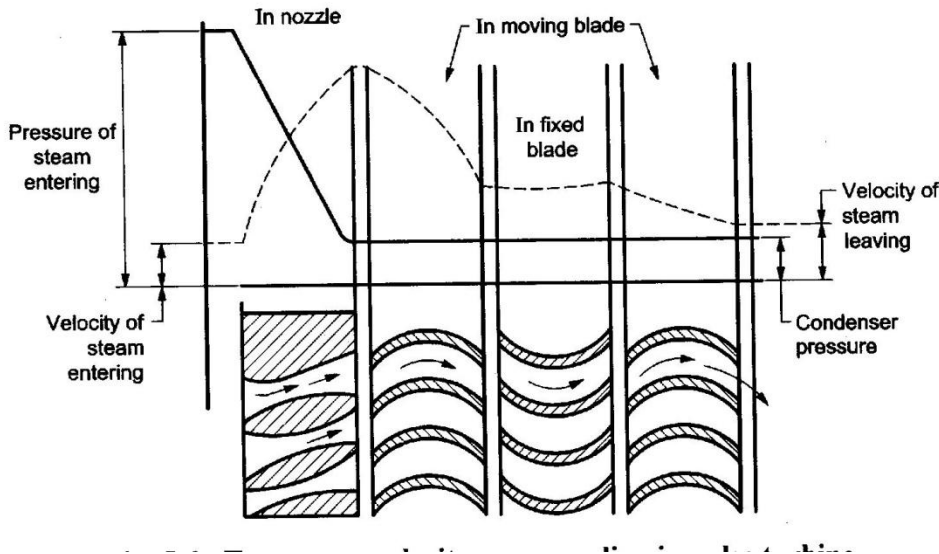

Fig: Variation of pressure and velocity

(b) (d) Velocity compounding (fig. – 2 marks, explanation -2 marks)

- The expansion of steam takes place in a nozzle or a set of nozzles from the boiler pressure to the condenser pressure.
- The steam, after expansion in nozzles, enters the first ring of moving blades at a high velocity. A portion of high velocity is absorbed by this blade ring & remaining is passed on to the next ring of fixed blades. The fixed blades change the direction of steam & direct it to the second ring of moving blades, without altering the velocity appreciably. After passing through this second ring of moving blades, a further portion of velocity is absorbed.
- All pressure drops occurs in the nozzles.



(e) Define

(each 2 marks)

(i) **Vacuum efficiency** – defined as the ratio of actual vacuum to the ideal vacuum.

$$\text{vacuum efficiency} = \frac{\text{Actual vacuum}}{\text{Ideal vacuum}}$$

Where , Actual vacuum = Barometric pressure – actual pressure

Ideal pressure = Barometric pressure – ideal pressure

(ii) **Condenser efficiency** – defined as the ratio of temperature rise of cooling water to the vacuum temperature minus inlet cooling water temperature.

$$\text{Condenser efficiency} = \frac{\text{Temp. rise of cooling water}}{\text{Vacuum temp.} - \text{Inlet cooling water temp.}}$$

$$\text{Condenser efficiency} = \frac{t_o - t_i}{t_v - t_i}$$

Where, t_o - Outlet temp. of cooling water.

t_i - inlet temp. of cooling water.

t_v - Vacuum temp . It is the saturation temp. corresponding to the condenser pressure.

(f) Given, condenser vacuum = 705 mm; Barometric pressure = 760 mm of Hg;

$t_i = 31^\circ \text{C}$; $t_o = 38^\circ \text{C}$

Pressure in the condenser = $760 - 705 = 55$ mm of Hg

$$= 55 \times 0.00133 = 0.07315 \text{ bar}$$

From steam table, corresponding to pressure of 0.07315 bar , we find that vacuum temp. (sat. Temp.)

$t_v = 39.8^\circ \text{C}$.



$$\text{Condenser efficiency} = \frac{t_o - t_i}{t_v - t_i} = \frac{38 - 31}{39.8 - 31} = 0.795 = 79.5\%$$

Q.5 Attempt any two of the following:

a) Cooling tower: (any1) (2 M for figure and 2 M for explanation)

i) **Forced draft cooling tower:** forced draft cooling tower consist of spray nozzles, circulating pipelines, water tank, nozzles fan, pump and valves.

- Basically water is sprayed from topside by using spray nozzle.
- Air is taken inside by using fan. They flow in opposite direction.
- Fan is provided at bottom of tower as shown in figure. Make up water is supplied as and when required.

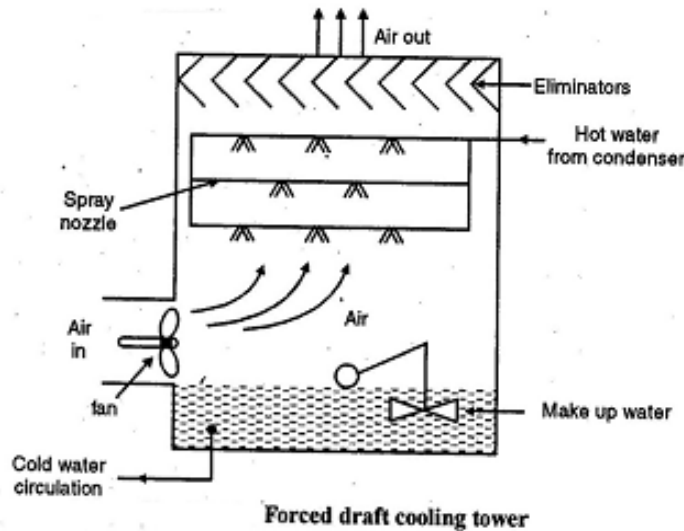

ii) **Induced draft cooling tower:** It consist of fan motor, eliminators, spray nozzles and water tank.

Fan is fixed at the topmost side as shown in figure.

- Air is induced from the inner space in which hot water is sprayed from the top.
- The mixing of water- air generates normal water, which is collected at bottom in water tank.
- Water can be recirculated by using pump. Make up water is added if needed.

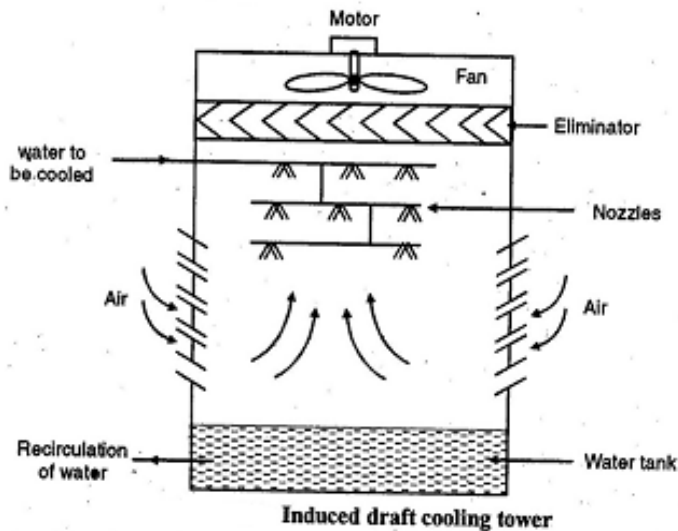

iii) Natural draft cooling tower:

- In natural draft cooling tower, hot water is pumped to ring troughs.
- Trough sprays water in the form of droplets, which is placed at bottom of towers.
- Most advantage is of no use of fan, for air circulation.
- An air circulation takes place by the pressure difference of air inside and outside of cooling tower (natural flow).

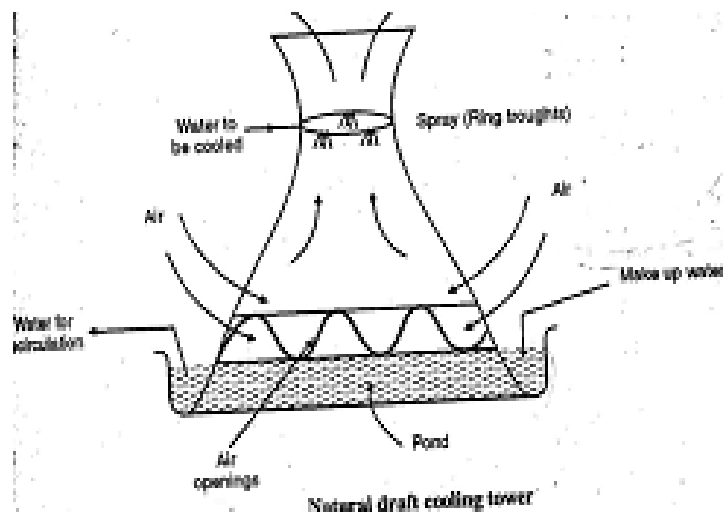

ii) Sources of air leakages: The main sources of air leakages in condenser are given below,

- The air leaks through the joints, packing and glands into the condenser as the pressure inside are below the atmospheric pressure.



- b) The feed water contains air in dissolved condition. The dissolved air gets liberated when steam is formed and it is carried with the exhaust steam into the condenser.
- c) In case of jet condenser, dissolved air with the cooling water enters into condenser. (2M)

Effects of air leakages in a condenser: (2M)

- a) It increases the back pressure of the prime mover and reduces the work done per kg of steam.
- b) The partial pressure of steam and its corresponding temperature decreases due to pressure of air.
- c) Because of poor thermal conductivity of air the rate of heat transfer from the vapour is reduced.

• **Surface condensers: (4M- figure, 4M- explanation)**

In this type of condenser, the cooling water and exhaust steam do not come in direct contact with each other. This type is generally used where large quantities of inferior water are available and where better quality of feed water to the boiler must be used.

It consists of an air tight cylindrical shell closed at each end as shown in the figure. A number of water tubes are fixed in the tube plates which are located between each cover head and shell.

The exhaust steam from the prime mover enters at the top of the condenser and surrounds the condenser tubes through which cooling water is circulated under force. The steam gets condensed as it comes in contact with the cold surface of the tubes. The cooling water flows in one direction through the first set of the tubes situated in the lower half of condenser and returns in opposite direction through the second set of the tubes situated in upper half of the condenser. The warm cooling water coming out from the condenser is discharged into cooling tower, river or cooling pond. The condensate is taken out from the condenser by a separate extraction pump and air is removed by an air pump.

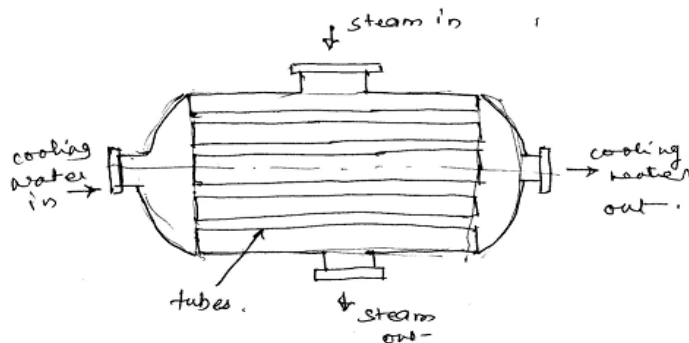

c) **Classification of boilers: (8 M)**

1. **Depending upon the relative position of water and flue gases:**



- **Smoke tube or fire tube boilers:** In these types of boilers the hot gases or the flue gases from the furnace are passed through the tubes surrounded by the water outside to be evaporated. Eg. Cochran, Lancashire, locomotive tec.
- **Water tube boilers:** In these boilers the water to be evaporated passes through the tubes and the gases from the furnace are passed over the external surface of the tubes. Eg. Babcock- Wilcox, Stirling boilers etc.

2. Depending upon the position of furnace:

- **Internally fired boilers:** in these the furnace is inside the body of the boiler shell. Eg. Locomotive and Lancashire boilers etc.
- **Externally fired boilers:** in these the furnace is outside the boiler shell. Eg. loeffler boilers, Babcock- Wilcox, Stirling boilers etc.

3. Depending upon the position of axis of the boiler:

- **Vertical boilers:** In which the axis of the boiler shell is in vertical plane.
- **Horizontal boilers:** In which the axis of the boiler shell is in horizontal plane.

4. Depending upon the service to which the boilers are put:

- Stationary, portable, marine or locomotive boilers etc.

5. Depending upon the source of heat:

- Heat generated due to combustion of solid, liquid and gaseous fuels.
- Hot waste gases or electrical energy and atomic energy etc.

6. According to method of circulation of water and steam:

- **Natural circulation:** In case of natural circulation steam boilers, the water is circulated by natural convection which is set up due to heating water. The temperature gradient causes the density gradient along the length of the tube due to which water flows from high density water to low density water and steam. Eg. Babcock- Wilcox etc.
- **Forced circulation:** In case of forced circulation steam boilers, the water is circulated with the help of centrifugal pump driven by external source of power. Such a method of water circulation is usually employed in high pressure boilers. Eg. La-Mont and Loeffler boilers.

7. According to pressure of steam generated:

- **Low pressure:** the boiler which produce steam at less than 20 bars pressures are low pressure boilers.
- **High pressure:** the boilers which produce steam above 20 bars are called high pressure boilers. Eg. Babcock- Wilcox, Stirling, La-Mont boilers.

- 8. According to nature of draught employed:** when the fuel is burnt on the surface due to natural circulation of air, the draught is called natural or chimney draught. If the air is circulated with the help of fan driven by external source of power, the draught used is called artificial draught.

Q 6 Attempts (any two) from the following:

- a) i) Classification of heat exchangers: (4M.....any 4 from the following)

1. Classification according to construction:



- Tubular heat exchangers.
- Plate heat exchangers.
- Extended surface heat exchangers.
- Regenerative heat exchangers.
- 2. Classification according to transfer process:**
 - Indirect contact heat exchangers.
 - Direct contact heat exchangers.
- 3. Classification according to flow arrangement:**
 - Parallel flow exchangers.
 - Counter flow heat exchangers.
 - Cross flow heat exchangers.
- 4. Classification according to pass arrangement:**
 - Single pass arrangement.
 - Multi-pass arrangement.
- 5. Classification according to surface compactness:**
 - *Gas to liquid*
 - compact ($\beta \geq 700 \text{ m}^2/\text{m}^3$)
 - non compact ($\beta \leq 700 \text{ m}^2/\text{m}^3$)
 - *Liquid to liquid and phase change*
 - compact ($\beta \geq 400 \text{ m}^2/\text{m}^3$)
 - non compact ($\beta \leq 400 \text{ m}^2/\text{m}^3$)
- 6. Classification according to number of fluids:**
 - Two fluids.
 - Three fluids.
 - N-fluids.
- 7. Classification according to phase of fluid.**
 - Gas- liquid.
 - Liquid-liquid.
 - Gas-gas.

ii) Given: $T_1 = 280^\circ\text{C}$, $T_2 = 40^\circ\text{C}$ $K_1 = 0.115 \text{ W/mK}$, $K_2 = 58 \text{ W/mK}$, $x_1 = 0.008\text{m}$, $x_2 = 0.03\text{m}$ $Q = ?$

Sol: (Assuming unit area)
$$Q = \frac{T_1 - T_2}{\left(\frac{x_1}{K_1}\right) + \left(\frac{x_2}{K_2}\right)} \dots\dots\dots(2M)$$



$$= \frac{280-40}{\frac{0.008}{0.115} + \frac{0.03}{58}}$$

$$= 3424.5373 \text{ W/m}^2 = 3.424 \text{ KW/m}^2 \dots\dots\dots(2M)$$

b) Fourier’s law: “Fourier's law states that the rate of heat flow, dQ/dt , through a homogeneous solid is directly proportional to the area, A , of the section at right angles to the direction of heat flow, and to the temperature difference along the path of heat flow, dT/dx . (2M)

Stefan–Boltzmann law: It is also known as **Stefan's law**, states that the total energy radiated per unit surface area of a black body per unit time (known variously as the black-body irradiance, energy flux density, radiant flux, or the emissive power), j^* , is directly proportional to the fourth power of the black body’s thermodynamic T (also called absolute temperature). (2M)

ii) Applications of heat exchangers. (4M)

1. Food and beverage.
2. Petroleum / chemical processing.
3. Hydrocarbon processing.
4. Polymers.
5. Pharmaceuticals.
6. Industrial.
7. Energy and power.

c) Pipe in pipe heat exchangers: (4M-figure) (4M- explanation)

Hairpin heat exchangers (often also referred to as “double pipes”) are characterized by a construction form which imparts a U-shaped appearance to the heat exchanger. In its classical sense, the term double pipe refers to a heat exchanger consisting of a pipe within a pipe, usually of a straight-leg construction with no bends. However, due to the need for removable bundle construction and the ability to handle differential thermal expansion while avoiding the use of expansion joints (often the weak point of the exchanger), the current U-shaped configuration has become the standard in the industry.

Working: A double pipe heat exchanger, in its simplest form is just one pipe inside another larger pipe. One fluid flows through the inside pipe and the other flows through the annulus between the two pipes. The wall of the inner pipe is the heat transfer surface. The pipes are usually doubled back multiple times as shown in the diagram at the left, in order to make the overall unit more compact.

The term 'hairpin heat exchanger' is also used for a heat exchanger of the configuration in the diagram. A hairpin heat exchanger may have only one inside pipe, or it may have multiple inside tubes, but it will always have the doubling back feature. Some heat exchanger advertises the availability of finned tubes in a hairpin or double pipe heat exchanger. These would always be



longitudinal fins, rather than the more common radial fins used in a cross-flow finned tube heat exchanger. In double pipe heat exchanger design, an important factor is the type of flow pattern in the heat exchanger. A double pipe heat exchanger will typically be either counterflow or parallel flow. Cross flow just doesn't work for a double pipe heat exchanger. The flow pattern and the required heat exchange duty allow calculation of the log mean temperature difference. That together with an estimated overall heat transfer coefficient allows calculation of the required heat transfer surface area. Then pipe sizes, pipe lengths and number of bends can be determined.

